

Model LP122A-3100

Triplex Ceramic
Plunger Pump
Operating Instructions/
Repair and Service
Manual

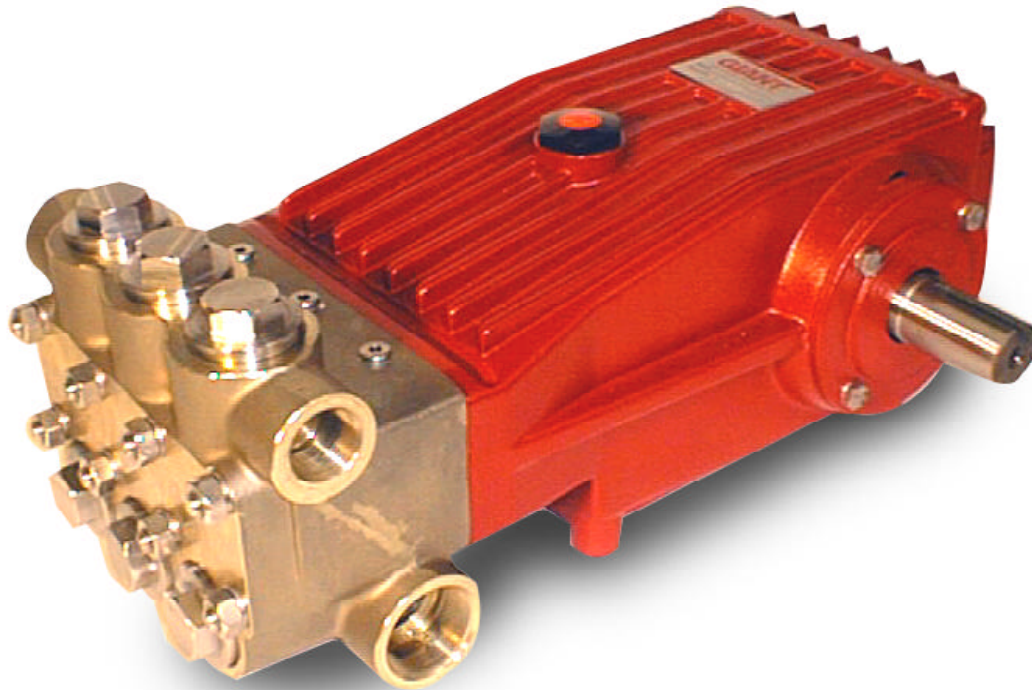

The word 'GIANT' in a bold, blocky, 3D-style font.

Contents:

Installation Instructions:	page 2
Recommended Spare	
Parts List:	page 2
Pump Specifications:	page 3
Exploded View:	page 4
Parts List/Kits:	page 5
Torque Specifications:	page 5
Trouble Shooting:	page 6
Repair Instructions:	pages 7
Dimensions:	back page
Warranty Information:	back page

Updated 10/02

INSTALLATION INSTRUCTIONS

Installation of the Giant Industries, Inc., pump is not a complicated procedure, but there are some basic steps common to all pumps. The following information is to be considered as a general outline for installation. If you have unique requirements, please contact Giant Industries, Inc. or your local distributor for assistance.

1. The pump should be installed flat on a base to a maximum of a 15 degree angle of inclination to ensure optimum lubrication.
2. The inlet to the pump should be sized for the flow rate of the pump with no unnecessary restrictions that can cause cavitation. Teflon tape should be used to seal all joints. If pumps are to be operated at temperatures in excess of 160⁰ F, it is important to insure a positive head to the pump to prevent cavitation. See NPSH curve.
3. The discharge plumbing from the pump should be properly sized to the flow rate to prevent line pressure loss to the work area. It is essential to provide a safety bypass valve between the pump and the work area to protect the pump from pressure spikes in the event of a blockage or the use of a shut-off gun.

4. Use of a dampener is necessary to minimize pulsation at drive elements, plumbing, connections, and other system areas. The use of a dampener with Giant Industries, Inc. pumps is optional, although recommended by Giant Industries, Inc. to further reduce system pulsation. Dampeners can also reduce the severity of pressure spikes that occur in systems using a shut-off gun. A dampener must be positioned downstream from the unloader.

5. Crankshaft rotation on Giant Industries, Inc. pumps should be made in the direction designated by the arrows on the pump crankcase. Reverse rotation may be safely achieved by following a few guidelines available upon request from Giant Industries, Inc. Required horsepower for system operation can be obtained from the charts on pages 3.

6. Before beginning operation of your pumping system, remember: Check that the crankcase and seal areas have been properly lubricated per recommended schedules. Do not run the pump dry for extended periods of time. Cavitation will result in severe damage. Always remember to check that all plumbing valves are open and that pumped media can flow freely to the inlet of the pump.

Finally, remember that high pressure operation in a pump system has many advantages. But, if it is used carelessly and without regard to its potential hazard, it can cause serious injury.

Preventative Maintenance Check-List & Recommended Spare Parts List						
Check	Daily	Weekly	50hrs	Every 500 hrs	Every 1500 hrs	Every 3000 hrs
Oil Level/Quality	X					
Oil Leaks	X					
Water Leaks	X					
Belts, Pulley		X				
Plumbing		X				
Recommended Spare Parts						
Oil Change p/n 1154			X	X		
Seal Spare Parts (1 kit/pump) (See page 5 for kit list)					X	
Oil Seal Kit (1 kit/pump) (See page 5 for kit list)					X	
Valve Spare Parts (1 kit/pump) (See page 5 for kit list)						X

IMPORTANT OPERATING CONDITIONS

Failure to comply with any of these conditions invalidates the warranty.

1. Prior to initial operation, add oil to the crankcase so that oil level is between the two lines on the oil dipstick. **DO NOT OVERFILL.**

Giant Recommended Oil

Crankcase oil should be changed after the first 50 hours of operation, then at regular intervals of 500 hours or less depending on operating conditions.

2. Pump operation must not exceed rated pressure, volume, or RPM. A pressure relief device must be installed in the discharge of the system.

3. Acids, alkalines, or abrasive fluids cannot be pumped unless approval in writing is obtained before operation from Giant Industries, Inc.

4. Run the pump dry approximately 10 seconds to drain the water before exposure to freezing temperatures.

NOTE: Contact Giant Industries for Service School Information. Phone: (419)-531-4600

Specifications

Model LP122A-3100

Volume	Up to 39.0 GPM (147.6 l/m)
Discharge Pressure	Up to 2000* PSI (138* Bar)
Inlet Pressure	Up to 90 PSI (6.2 Bar)
Speed	Up to 885 RPM
Plunger Diameter	42 mm
Stroke	42 mm
Crankcase Oil Capacity	116 fl.oz.
Temperature of Pumped Fluids	Up to 160°F (71°C)
Inlet Port	1-1/2" NPT
Discharge Port	1" NPT
Crankshaft Mounting	Either Side
Shaft Rotation	Top of Pulley Towards Fluid End
Weight	116 lbs.
Crankshaft Diameter	35 mm
Valve Casing - LP122A-3100	Aluminum Bronze-Nickle
Volumetric Efficiency @ 800 RPM.....	0.96
Mechanical Efficiency @ 800 RPM.....	0.85

PULLEY INFORMATION

Pulley selection and pump speed are based on a 1725 RPM motor and "B" section belts. When selecting desired GPM, allow for a ±5% tolerance on pumps output due to variations in pulleys, belts and motors among manufacturers.

1. Select GPM required, then select appropriate motor and pump pulley from the same line.
2. The desired pressure is achieved by selecting the correct nozzle size that corresponds with the pump GPM.

HORSEPOWER INFORMATION

We recommend that a 1.1 service factor be specified when selecting an electric motor as the power source. To compute specific pump horsepower requirements, use the following formula:

$$HP = (GPM \times PSI) / 1440$$

Pump speeds of 640 RPM and above require a minimum inlet pressure of 12 psig.
 Pump speeds of 805 RPM and above require a minimum inlet pressure of 14 psig.

LP122A-3100 PULLEY SELECTION AND HORSEPOWER REQUIREMENTS								
PUMP PULLEY	MOTOR PULLEY	GPM	RPM	600 PSI	800 PSI	1000 PSI	1300 PSI	2000 PSI*
12.75"	3.95"	22.3	500	9.6	12.7	15.9	20.7	31.9
12.75"	4.35"	24.7	555	10.6	14.1	17.6	22.9	35.3
12.75"	4.95"	28.5	640	12.2	16.3	20.4	26.5	40.7
12.75"	5.35"	30.9	695	13.2	17.7	22.1	28.7	44.1
12.75"	5.75"	33.4	750	14.3	19.1	23.9	31.0	47.7
12.75"	6.15"	35.6	800	15.3	20.3	25.4	33.1	50.9
12.75"	6.50"	39.4	885	16.9	22.5	28.1	36.6	56.3

*Intermittent duty only! - Consult factory!

Exploded View - LP122A-3100

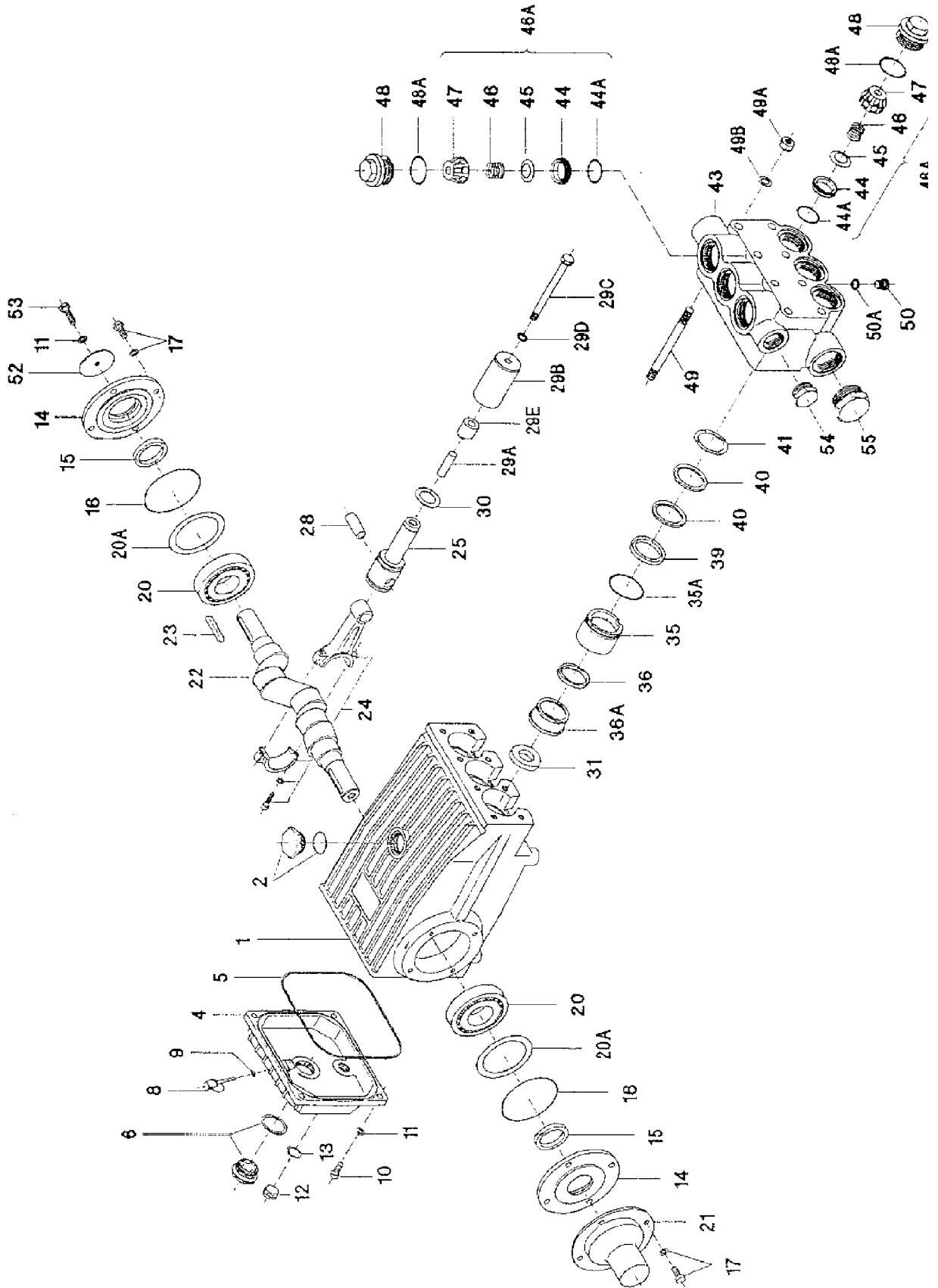

SPARE PARTS LIST - LP122A-3100 PUMP

ITEM	PART NO.	DESCRIPTION	QTY.	ITEM	PART NO.	DESCRIPTION	QTY.
1	07759	Crankcase	1	30	07779	Flinger	3
2	13000	Oil Filler Plug	1	31	07133	Radial Shaft Seal	3
4	06085	Crankcase Cover	1	35	13342-0100	Seal Sleeve	3
5	07104	O-Ring	1	35A	06619	O-Ring	3
6	07186	Oil Sight Glass W/Gasket	1	36	13415	Grooved Ring	3
8	06086	Oil Dipstick	1	36A	13416-0100	Pressure Ring	3
9	01009	O-Ring	1	39	07744-0100	Pressure Ring	3
10	08093	Screw	4	40	07745	Sleeve	6
11	08094	Spring Washer	5	41	06621-0100	Support Ring	3
12	12137	Oil Drain Plug	1	43	13018-3000	Valve Casing	1
13	07182	Gasket	1	44	07748-0300	Valve Seat	6
14	07111	Bearing Cover	2	44A	06620	O-Ring	6
15	07112	Crankshaft Seal	2	45	07749-0300	Valve Plate	6
16	07113	O-Ring	2	46	07750	Valve Spring	6
17	08095	HexScrew	8	47	07752	Spring Tension Cap	6
20	07116	Taper Roller Bearing	2	48	06089	Plug	6
20A	07117	Fitting Disc, 0.1mm	2	48A	06736	O-Ring	6
20B	13001	Fitting Disc, 0.15mm	3	49	07157	Stud Bolt	8
21	07118	Shaft Protector	1	49A	07158	Nut	8
22	13242	Crankshaft	1	49B	07159	Washer	8
23	13243	Key	1	50	07423-0100	Plug	1
24	13340	Connecting Rod Assy.	3	50A	07755-0100	Gasket	1
25	13341	Crosshead Plunger Base Assy.	3	52	13020	Disk for Crankshaft	1
28	13232	Crosshead Pin	3	53	06607	Hexagon Screw	1
29A	07735	Centering Sleeve	3	54	13321-0100	Plug 1" BSP	1
29B	07736	Plunger Pipe	3	55	13322-0100	Plug, 1" BSP	1
29C	07737-0100	Plunger Bolt	3				
29D	07161-0100	Gasket for Bolt	3				
29E	06618	Spacer Pipe	3				

LP122A-3100 Repair Kits

Plunger Kit

09575

Item	Qty.	Part#	Description
35A	3	06619	O-Ring
36	3	13145	Grooved Ring
39	3	07142-0100	Pressure Ring
40	6	07744	Sleeve

Oil Seal Kit

09577

Item	Qty.	Part#	Description
31	3	07133	Radial Shaft Seal

Valve Assembly Kit

#09576

Item	Qty.	Part #	Description
44	6	07748-0300	Valve Seat
44A	6	06620	O-Ring
45	6	07749-0300	Valve Plate
46	6	07750	Valve Spring
47	6	07752	Spring Tension Cap
48A	6	06736	O-Ring

LP122A-3100 TORQUE SPECIFICATIONS

Position	Item#	Description	Torque Amount
10	08093	Screw, Cover	125 in.-lbs.
17	08095	Hex Screw, Bearing Cover	125 in.-lbs.
24A	13277	Hex Screw, Connecting Rod	250 in.-lbs.
29C	07131-0100	Plunger Bolt	26 ft.-lbs.
48	06077-0100	Plug, Valve	160 ft.-lbs.
49A	07158	Nut, Stud Bolt	60 ft.-lbs.

PUMP SYSTEM MALFUNCTION

<u>MALFUNCTION</u>	<u>CAUSE</u>	<u>REMEDY</u>
The Pressure and/ or the Delivery Drops	Worn packing seals Broken valve spring Belt slippage Worn or Damaged nozzle Fouled discharge valve Fouled inlet strainer Worn or Damaged hose Worn or Plugged relief valve on pump Cavitation Unloader	Replace packing seals Replace spring Tighten or Replace belt Replace nozzle Clean valve assembly Clean strainer Repair/Replace hose Clean, Reset, and Replace worn parts Check suction lines on inlet of pump for restrictions Check for proper operation
Water in crankcase	High humidity Worn seals	Reduce oil change interval Replace seals
Noisy Operation	Worn bearings Cavitation	Replace bearings, Refill crankcase oil with recommended lubricant Check inlet lines for restrictions and/or proper sizing
Rough/Pulsating Operation with Pressure Drop	Worn packing Inlet restriction Accumulator pressure Unloader Cavitation	Replace packing Check system for stoppage, air leaks, correctly sized inlet plumbing to pump Recharge/Replace accumulator Check for proper operation Check inlet lines for restrictions and/or proper size
Pressure Drop at Gun	Restricted discharge plumbing	Re-size discharge plumbing to flow rate of pump
Excessive Leakage	Worn plungers Worn packing/seals Excessive vacuum Cracked plungers Inlet pressure too high	Replace plungers Adjust or Replace packing seals Reduce suction vacuum Replace plungers Reduce inlet pressure
High Crankcase Temperature	Wrong Grade of oil Improper amount of oil in crankcase	Giant oil is recommended Adjust oil level to proper amount

REPAIR INSTRUCTIONS - LP122A-3100

NOTE: Always take time to lubricate all metal and non-metal parts with a light film of oil before reassembling. This step will help ensure proper fit, at the same time protecting the pump non-metal parts (elastomers) from cutting and scoring.

TO CHECK VALVES

Screw off tension plugs (48) and remove O-ring. Take out discharge valve, pulling them upwards out of the valve casing with snap-ring tongs or any other pull-off device. Then remove suction valves in the same way. Loosen valve seals (46A) from spacer pipe by lightly hitting the valve plate (46B) with a plastic stick. Check sealing surface and replace worn parts. Reassemble with new O-rings if possible and oil them before installing. Tighten up tension plugs (48) to 107 ft.-lbs. (145 Nm).

TO CHECK SEALS AND PLUNGER PIPE

Loosen the 8 nuts (49A) and pull off valve casing to the front. Pull seal sleeves (35) out of guides in crankcase. Remove seal case (37) and tension spring (42) from seal sleeve. Check plunger surface and seals. If plunger pipe is worn out, loosen tension screws (29C) and pull off plunger pipe to the front. Clean front surface of plunger (25) thoroughly. Then place new plunger pipe carefully through the oiled seals and push seal sleeve with plunger pipe into the crankcase guide. Turn gear until the plunger (25) comes up against the plunger pipe. Put a new copper gasket (29D) onto tension screw (29C). Put a thin coat of glue (Loctite) on the gasket and tighten screw to 310 in.-lbs. (35 Nm).

CAUTION: Care must be taken that no glue gets between the plunger pipe (29B) and the centering sleeve (29A). The plunger pipe should not be strained by eccentric tightening of the tension screw or through damage to front surface of plunger, otherwise it will probably break. Tighten the fixing nuts (49A) for the valve casing evenly at 59 ft.-lbs. (80 Nm).

TO DISMANTLE GEAR

After removing valve casing and plunger pipe, drain oil. Screw off gear cover (4) and bearing cover (14). Loosen con rod screws and push the front of the con rod forward as far as possible into the crosshead guide.

CAUTION: Connecting rods are marked for identification. Do not twist con rod halves. Con rod is to be reinstalled in the same position on shaft journals.

Turning the crankshaft slightly, hit it out carefully to the side with a rubber hammer.

CAUTION: Do not bend the con rod shanks. Check shaft and con rod surfaces, shaft seals and taper roller bearings.

TO REASSEMBLE

Using a soft tool, press in the outer bearing ring till the outer edge lines up with the outer edge lines up with the outer edge of the bearing hole. Screw off bearing cover together with shaft seal and O-ring. Fit shaft through bearing hole on the opposite side. Press in outer bearing and tension it inwards with the bearing cover, keeping the shaft in vertical position and turning slowly so that the taper rollers of the bearing touch the edge of the outer bearing ring. Adjust bearing clearance to at least 0.1mm and maximum 0.15mm by placing fitting discs (20A) under the bearing cover.

CAUTION: After assembly has been complete, the shaft should turn easily with very little clearance. Tighten con rod screws to 310 in.-lbs. (35 Nm).

LP122A-3100 DIMENSIONS - INCHES (mm)

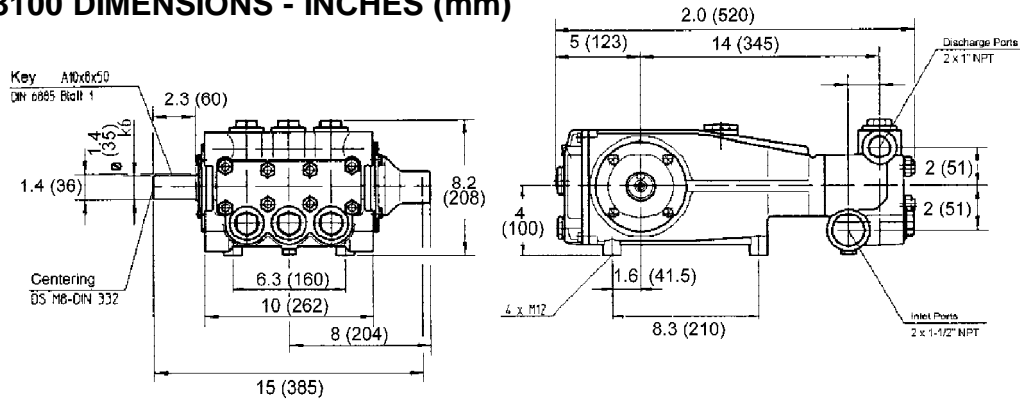

GIANT INDUSTRIES LIMITED WARRANTY

Giant Industries, Inc. pumps and accessories are warranted by the manufacturer to be free from defects in workmanship and material as follows:

1. For portable pressure washers and self-service car wash applications, the discharge manifolds will never fail, period. If they ever fail, we will replace them free of charge. Our other pump parts, used in portable pressure washers and in car wash applications, are warranted for five years from the date of shipment for all pumps used in NON-SALINE, clean water applications.
2. One (1) year from the date of shipment for all other Giant industrial and consumer pumps.
3. Six (6) months from the date of shipment for all rebuilt pumps.
4. Ninety (90) days from the date of shipment for all Giant accessories.

This warranty is limited to repair or replacement of pumps and accessories of which the manufacturer's evaluation shows were defective at the time of shipment by the manufacturer. The following items are NOT covered or will void the warranty:

1. Defects caused by negligence or fault of the buyer or third party.
2. Normal wear and tear to standard wear parts.
3. Use of repair parts other than those manufactured or authorized by Giant.
4. Improper use of the product as a component part.
5. Changes or modifications made by the customer or third party.
6. The operation of pumps and or accessories exceeding the specifications set forth in the Operations Manuals provided by Giant Industries, Inc.

Liability under this warranty is on all non-wear parts and limited to the replacement or repair of those products returned freight prepaid to Giant Industries which are deemed to be defective due to workmanship or failure of material. A Returned Goods Authorization (R.G.A.) number and completed warranty evaluation form is required prior to the return to Giant Industries of all products under warranty consideration. Call (419)-531-4600 or fax (419)-531-6836 to obtain an R.G.A. number.

Repair or replacement of defective products as provided is the sole and exclusive remedy provided hereunder and the MANUFACTURER SHALL NOT BE LIABLE FOR FURTHER LOSS, DAMAGES, OR EXPENSES, INCLUDING INCIDENTAL AND CONSEQUENTIAL DAMAGES DIRECTLY OR INDIRECTLY ARISING FROM THE SALE OR USE OF THIS PRODUCT.

THE LIMITED WARRANTY SET FORTH HEREIN IS IN LIEU OF ALL OTHER WARRANTIES OR REPRESENTATION, EXPRESS OR IMPLIED, INCLUDING WITHOUT LIMITATION ANY WARRANTIES OR MERCHANTABILITY OR FITNESS FOR A PARTICULAR PURPOSE AND ALL SUCH WARRANTIES ARE HEREBY DISCLAIMED AND EXCLUDED BY THE MANUFACTURER.



GIANT INDUSTRIES, INC., 900 N. Westwood Avenue, P.O. Box 3187, Toledo, OH 43607
PHONE: (419) 531-4600, FAX: (419) 531-6836, www.giantpumps.com
© Copyright 2002 Giant Industries, Inc.